



Digital version

## ENGS252 Signals and Systems - Homework 10

Mher Saribekyan A09210183

April 27, 2026

### Problem 1

Write the difference equation for the negative feedback system with open loop gain  $G_{op} = 1000$  and feedback path gain  $G_{feed} = 0.6$  and delay equal to one sample. Draw the corresponding block diagram.

$$y[n] = 1000x[n] - 600y[n - 1]$$

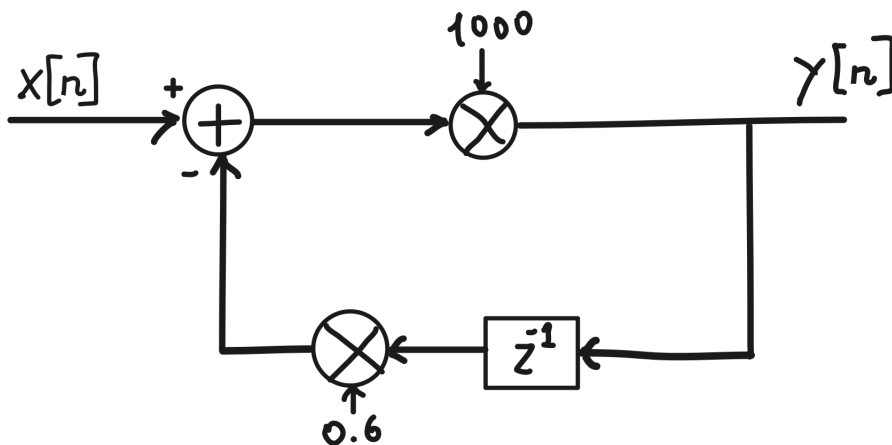

### Problem 2

Draw the block diagram of the causal discrete-time linear time-invariant filter with input  $x[n]$  and output  $y[n]$  is governed by the following difference equation:

$$y[n] = 0.8y[n - 1] + x[n] - 1.25x[n - 1]$$

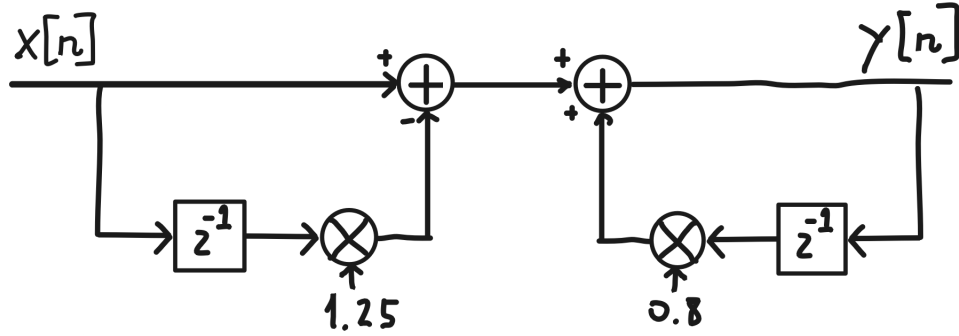

### Problem 3

Derive the closed-form expression of the impulse response  $h[n]$  of the combined system consisting of systems governed by the given difference equations, with input  $x[n]$  and output  $y[n]$ , if the systems are connected parallel and in series. List the first four values of the impulse response of the combined system.

$$y_1(n) = 3x_1(n) + 2x_1(n-1) - \frac{1}{3}y_1(n-1) \text{ and } y_2(n) = 2x_2(n) - 3x_2(n-1) - \frac{1}{4}y_2(n-1)$$

$$h_1[0] = 3, h_1[2] = 1, h_1[3] = -\frac{1}{3}, h_1[4] = \frac{1}{9},$$

$$h_2[0] = 2, h_2[2] = -\frac{7}{2}, h_2[3] = \frac{7}{8}, h_2[4] = -\frac{7}{32},$$

Therefore, we can draw conclusion that the impulse responses are:

$$h_1[n] = 3\delta[n] + \delta[n-1] - \left(\frac{1}{3}\right)^{n-2} u[n-2]$$

$$h_2[n] = 2\delta[n] - \frac{7}{2}\delta[n-1] - \frac{7}{8}\left(\frac{1}{3}\right)^{n-2} u[n-2]$$

a) in parallel

$$h_{\text{parallel}}[n] = h_1[n] + h_2[n] = 5\delta[n] - \frac{5}{2}\delta[n-1] - \left(\left(\frac{1}{3}\right)^{n-2} + 0.875\left(\frac{1}{3}\right)^{n-2}\right) u[n-2]$$

$$h[0] = 5, h[1] = -\frac{5}{2}, h[2] = \frac{13}{24}, h[3] = -\frac{31}{288}$$

b) in series (cascade connection)

$$\begin{aligned} h_{\text{series}}[n] &= h_1[n] * h_2[n] = \sum_{k=-\infty}^{+\infty} h_1[k] \cdot h_2[n-k] = \sum_{k=0}^{\infty} h_1[k] \cdot h_2[n-k] \\ &= \sum_{k=0}^{\infty} \left( 3\delta[k] + \delta[k-1] - \left(\frac{1}{3}\right)^{k-2} u[k-2] \right) \cdot \left( 2\delta[n-k] - \frac{7}{2}\delta[n-k-1] - \frac{7}{8}\left(\frac{1}{3}\right)^{n-k-2} u[n-k-2] \right) \end{aligned}$$